

LET'S **GROW** 
TOGETHER

PICANOL

EN

OMNI*plus* Summum

ABOUT THE PICANOL GROUP

The Picanol Group is an international, customer-focused group specialized in the development, production and sale of weaving machines, engineered casting solutions and custom-made controllers.

Its Weaving Machine division (Picanol) develops, produces and sells advanced weaving systems based on airjet or rapier insertion technology. Picanol has played a pioneering role around the world for more than 75 years, and is now one of the world's leading producers of weaving machines.

The Industries division covers all the other activities not related to weaving machines. Proferro represents the group's metal casting and mechanical finishing activities. It produces cast iron parts for among other things compressors and agricultural machinery, as well as parts for Picanol weaving machines. PsiControl for its part develops and produces custom-made controllers, Human Machine Interface (HMI) and touch devices. Finally, Melotte develops and manufactures innovative product solutions using 3D printing.



Since 2013 the Picanol Group has also had a leading stake in the Tessenderlo Group (TESB).

In addition to its headquarters in Ieper (Belgium), the Picanol Group has production facilities in Asia and elsewhere in Europe, backed up by its own worldwide sales and services network. The Picanol Group employs some 2,000 people around the world, and has been listed on the Euronext Brussels exchange (PIC) since 1966.

TRAINING TAKES YOUR TALENT FURTHER

Well-trained employees are a real asset to your company. Skilled staff make your machines run at optimum performance, producing excellent fabric quality and resulting in superb plant efficiency.

Training is part of the deal Picanol makes with its customers. We feel it is our duty to help your employees to improve their skills and knowledge. Hence, in 2015 we decided to invest in a state-of-the-art Technical Training Center in Ieper. Three fully equipped rooms (each with weaving machines, cut models, mini workshop etc.) cover a total area of 270 m². This new knowledge center allows Picanol to train technicians from customers around the world in optimal conditions. All facilities are there to give your employees a warm welcome. If your employees are not able to travel to one of our training centers, our instructors come to you and will organize training at your premises.

Next to Ieper, Picanol has two first-in-class training centers located in Suzhou (China) and Greenville (USA). All our training centers are specialized in technical training on weaving machines for machine operators, fitters and weaving managers.

A full list of our training courses can be found on our website: <http://www.picanol.be>

Our team is always at your disposal for further information or questions. Contact: ttc-ieper@picanol.be (tel. +32 57 22 21 11).



SPARE PARTS

Weaving machines are one of your most important investments. Keeping them in optimal condition is essential to safeguard the high value of this asset and to remain competitive as a weaver in a globalizing world.

Use of original Picanol parts guarantees a continued high performance of the Picanol weaving machines.

Moreover, timely replacement of original parts enables Picanol's customers to run their machines in the most economical way.

Regardless of the age of the machine, the use of original parts will keep the machine in top condition which has a positive influence on the value of the machine throughout its life time.

Furthermore, to expand your weaving range and/or increase your machine performance, Picanol offers upgrade packages for installed Picanol machines. WeaveUp upgrades add state-of-the-art technology to your machines, which apart from the benefits in weaving equally increase the value of your investment.

With special services and a dedicated aftermarket team, Picanol takes care of the particular requirements and requests of its customers around the globe. These tailored solutions include among others :

- Online ordering of spare parts through P@rtsline
- Electronic spare parts catalogue (eSPC)
- On-time delivery of high-quality original parts
- Harness frames for different brands of weaving machines
- Tailor made upgrade proposals for installed machines
- Analysis and recommendations in respect with running costs
- Preventive maintenance and service audits

With headquarters in Belgium and local offices in China, India, Indonesia, Turkey, USA, Mexico, Brazil, Picanol is able to assure a close, long-term relationship with all its customers.

For more information, please contact your local Customer Service Representative (CSR).





OMN*iplus* Summum

The new standard in airjet weaving

PICANOL

OMN*iplus* Summum



LET'S GROW TOGETHER

PICANOL



The OMNlplus Summum is Picanol's latest generation in airjet weaving machines, combining the latest available technology with over 30 years of experience in airjet weaving.

By combining state-of-the-art technology in hard- and software, the OMNlplus Summum offers your weaving plant the next upgrade to meet new market demands in quality, performance and energy consumption.

Built on the new BlueBox platform, the OMNlplus Summum is packed with new features that enhance your weaving performance and allow us to continue adding improvements in the future. With its superior microprocessor performance and memory capacity, the platform is ready to meet the hardest working conditions now and in the future.

With the OMNlplus Summum our customers get fully electronic pressure regulators, a separate built-in air tank for each weaving channel and a unique triple air tank configuration for the relay nozzles. This significantly improves the user-friendliness and flexibility of the machine. Combined with the new BlueBox system, all the available data are translated into optimal settings for maximum performance and minimum air consumption without compromising on performance, flexibility and energy.

This Picanol machine is characterized by its robust structure and offers the highest stability and performance on the market. Flexibility in weaving a wide range in fabrics is achieved by its modular design. Add-on modules and aftermarket "WeaveUps" provide the versatility, efficiency and perfection you need for your investment.

Our LoomGate remote monitoring solution allows customers to check the performance of the entire weaving mill at any time, anywhere they like. Performance data such as produced picks, efficiency, average speeds, number of stops and much more can be exported for reporting and optimization purposes.

SEPARATE AIR TANK PER WEAVING CHANNEL

Air tanks built into the machine side frame: enables optimal setting by means of an electronic pressure regulator for each individual weaving channel.

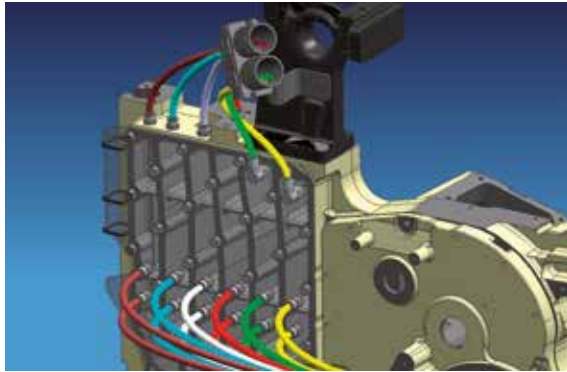

DEDICATED SLEY CAM VERSIONS

Dedicated sley cam versions make it possible to weave the most demanding fabrics and yarns. Also available for larger-width applications, thanks to optimization of the available insertion time.

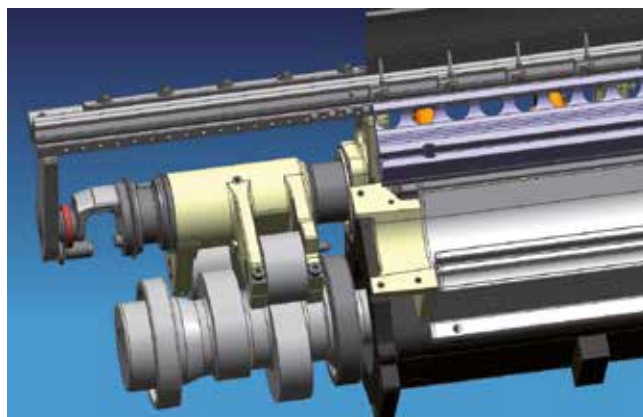

ROBUST STRUCTURE

Proven Picanol design. Two solid side frames connected by large-section cross bars, with the sley driven at both sides by conjugated cams. This configuration offers the required machine stability and the highest beat-up force, making it possible to weave any kind of fabric successfully.

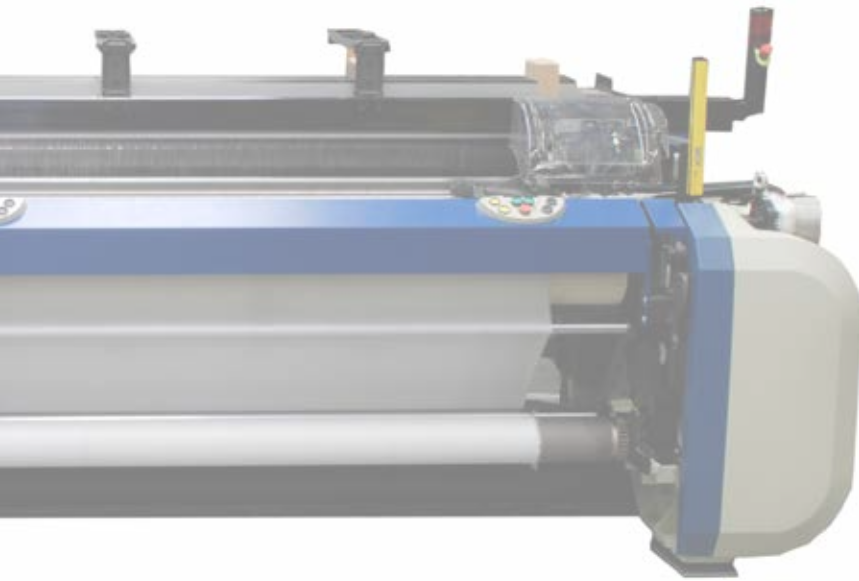
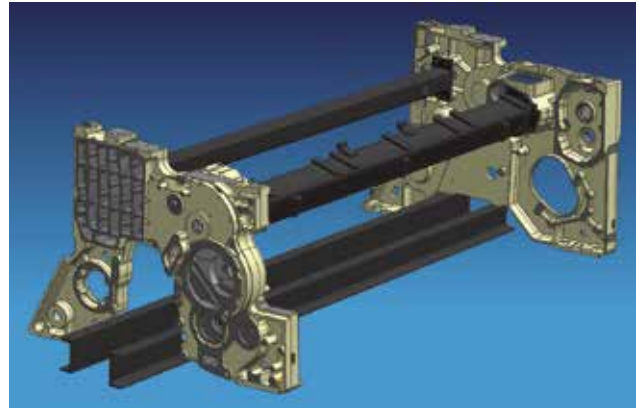

FIXED AND MOVABLE MAIN NOZZLES

The most efficient nozzles for all yarn types, adaptable with nozzle clamps for heavy stretching yarns. Jet funnel for guiding multiple channels into the reed tunnel.



LET'S GROW 
YOUR MARKET

E-LENO

Independent setting of crossing timing left to right. A guarantee of maximum flexibility in setting. Easy repositioning for flexibility in weaving widths.

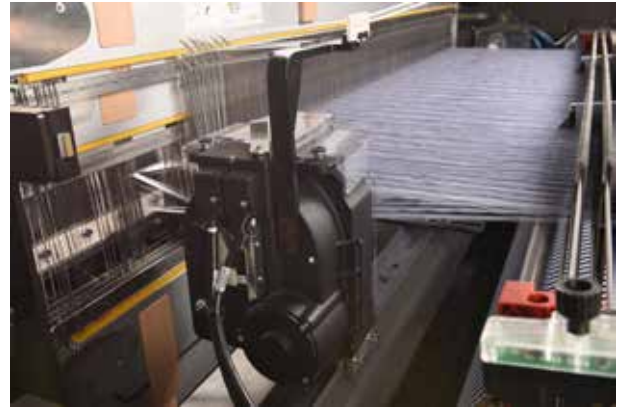

BUILT-IN PRESSURE SENSOR

Indication of pressure levels throughout the machine. Machine behavior adjusted according to the air supply pressure.

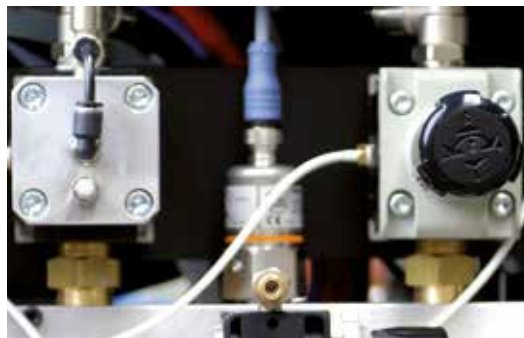

ELECTRONIC PRESSURE REGULATORS

Significantly improved pressure build-off time in the main nozzles thanks to the new configuration of the air preparation. Result: reduced impact on the filling yarn, bringing a real advantage when handling delicate or weak yarns.

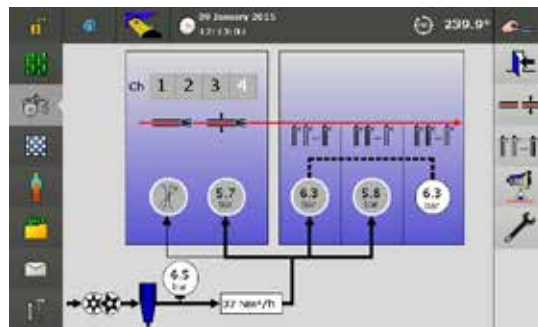

UNIQUE TRIPLE AIR TANK CONFIGURATION

Lower air pressure on center air tank, minimizing impact from the relay nozzles on the fabric. Enables the user to set the machine with lowest possible pressure and reduce air consumption by up to 15% without compromising on fabric quality.

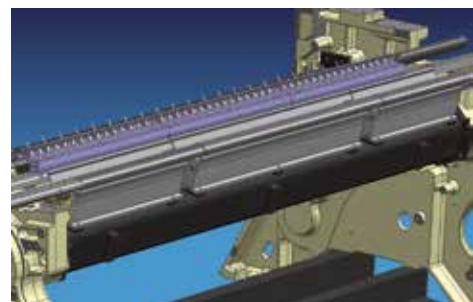

ELECTRONIC LENO SYSTEM (ELSY)

With individual programming of the weaving pattern.
Creating unlimited possibilities for weaving the fabric selvedge.

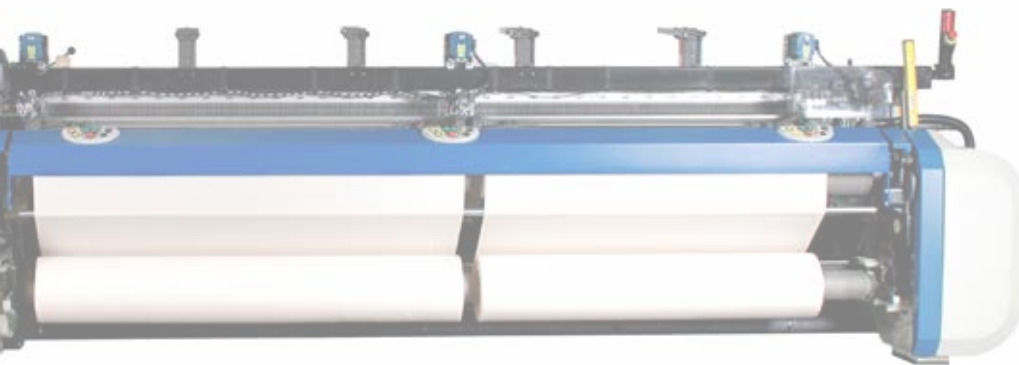

SMART ARGUS

Continuous monitoring of correct weft yarn number. Possible to check the position of the filling yarn in the reed channel at the end of insertion and make corrections.



TWIN STRETCH NOZZLE

Add that extra stretch to prevent flip-backs throughout the fabric and increase productivity with kinky fabrics. Simple but universal mounting solution for a wide range of products.



GET THE MOST 
OUT OF YOUR MATERIAL

UNIQUE PICANOL RELAY NOZZLE DESIGN

Picanol has developed relay nozzles that offer an optimal performance/consumption ratio. One of the main reasons why air consumption is fully under control on the OMN*l*plus Summit. Different types of nozzles are available for a wide range of yarns.

Multi-hole: offers the highest traction force and is the choice when no compromises can be made on the weaving speed.

EcoOne: designed to achieve the best balance between speed, air consumption and maintenance, capable of weaving even under the most dusty and fluffy conditions.

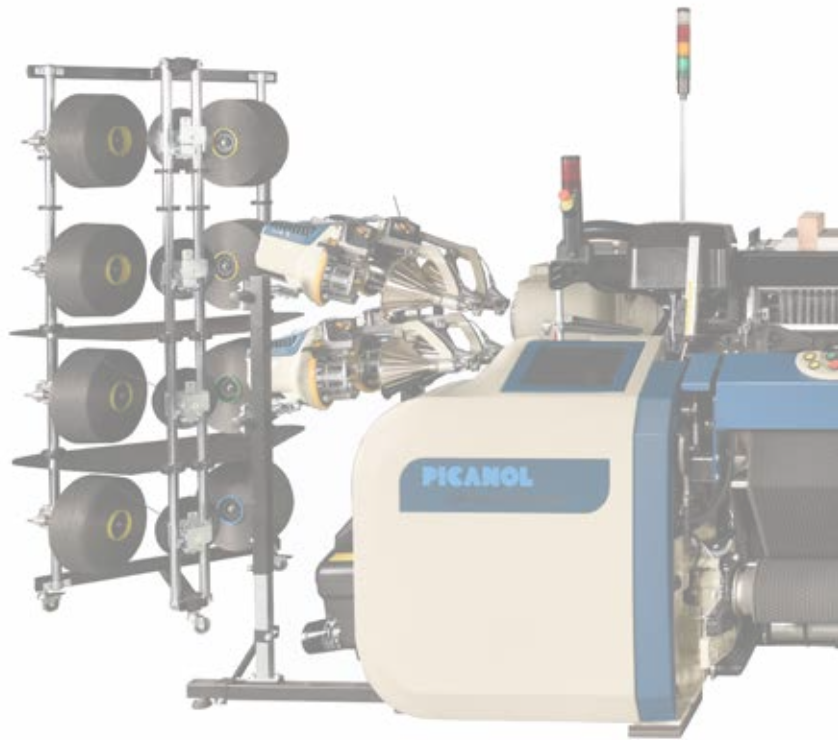
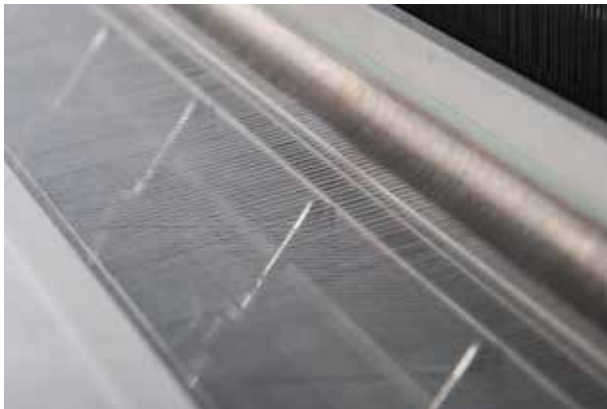

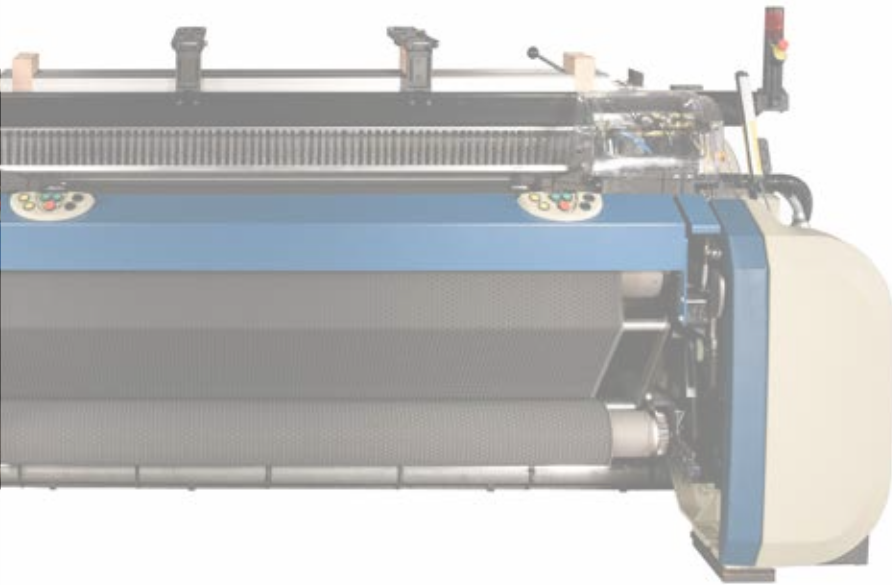

SUMO MAIN MOTOR

Fastest and most stable machine start-up. Reduced power consumption thanks to reduced drive train (fewer gears, less friction). Integrated machine concept fully synchronized with all the other electrically driven motors: Electronic Take-Up (ETU) and Let-Off (ELO). Common power supply: real-time speed adjustment and recuperation of braking energy.

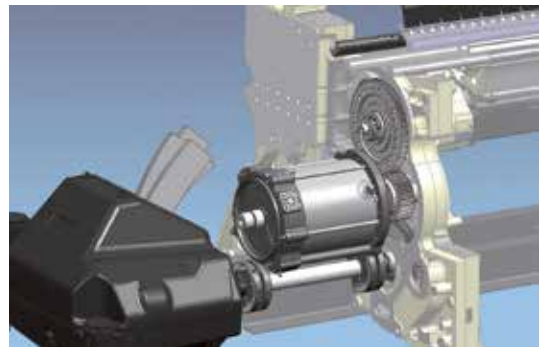
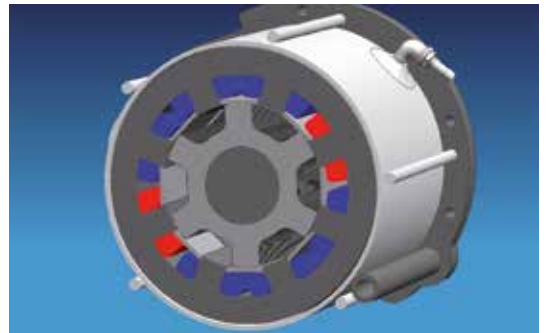

GET THE MOST 
OUT OF YOUR ENERGY

ELECTRONIC PRESSURE REGULATORS

Full control over pressure settings for main and relay nozzles. All settings can be optimized from the machine terminal.

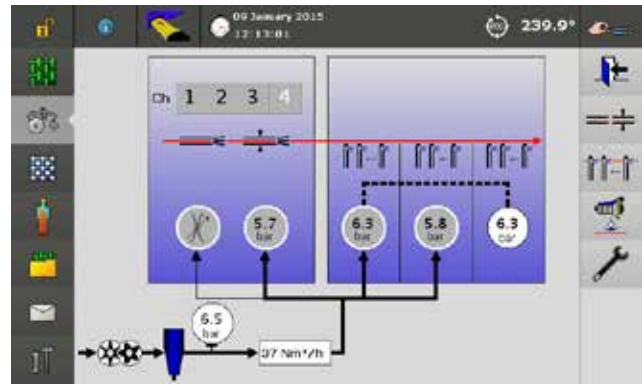

ARVD II PLUS

Automatic optimization of relay nozzle blowing timings, saving up to 20% on air consumption.

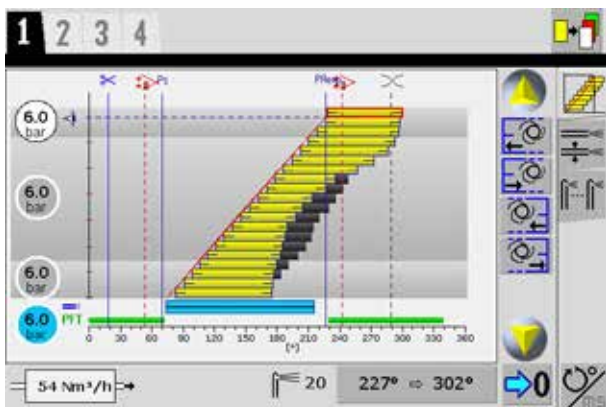

AIRMASTER

Monitors and manages air consumption.
Automatically checks the consumption of each individual insertion component by means of an automated diagnostic procedure.

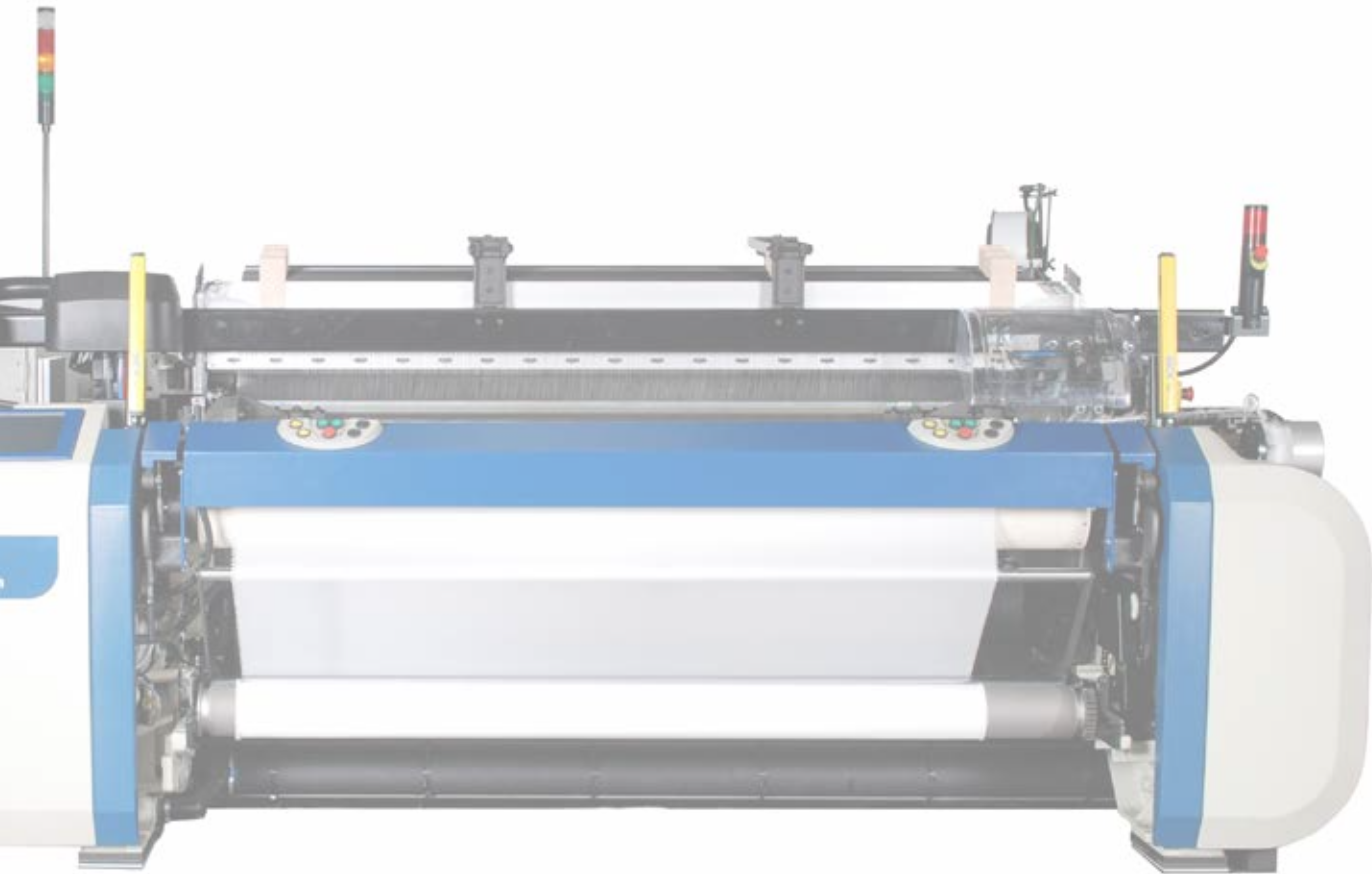

GET THE MOST 
OUT OF YOUR ENERGY

PICANOL BLUEBOX SYSTEM

Future-proof platform with optimal microprocessor speeds, increased memory capacity and modular circuit board setup. Network connectivity allows for remote monitoring and service. Picanol BlueBox is the electronic platform to keep up with increasing requirements for modern weaving mills and be ready for future developments.



AUTOMATIC CROSSING MOMENT

Direct, unique mechanical configuration – all machines have full pick finding as standard. The crossing timing of the shedding motion can be set from the machine display – no tools required!

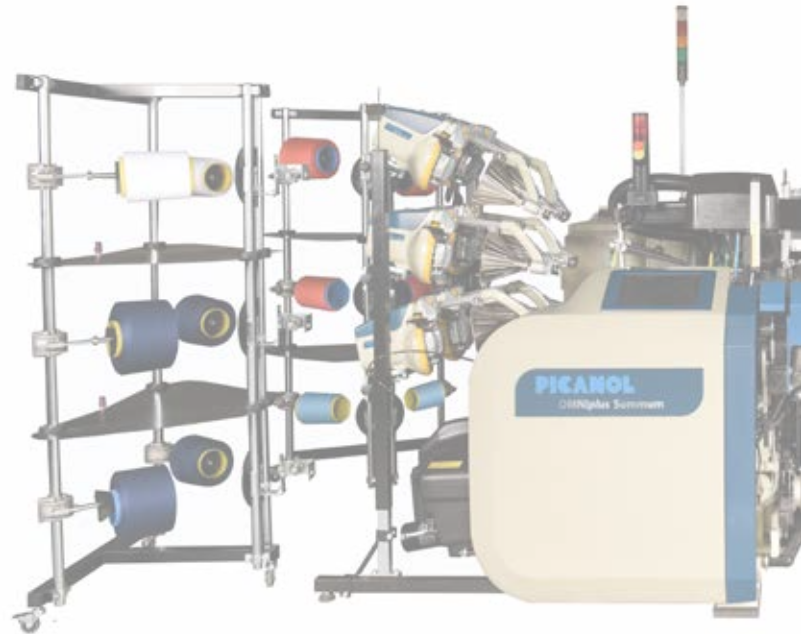

SPEED ADJUSTMENT

Machine speeds can be set and adjusted on the machine display. Changing the speed can be done in real time using Multispeed or automatically following a pre-programmed speed pattern, for which Optispeed is needed. Makes it very easy to set the best speed for a given style on a running machine.



AIR TUCKING-IN FOR CONTINUOUS REEDS

Unique! Great ease of setting and maintenance.
Tucking-in no longer puts limitations on machine speeds, unlike mechanical tucking-in.



PICK REPAIR AUTOMATION (PRA II PLUS)

In case of a machine stop (filling stop), the new PRA II Plus system automatically removes the filling from the shed and starts the machine again if conditions allow this. The new PRA II Plus system combines pneumatic and mechanical actions for removing the yarn, making it unique in its kind.

A guarantee of the highest possible success rate and lowest load for the weavers!

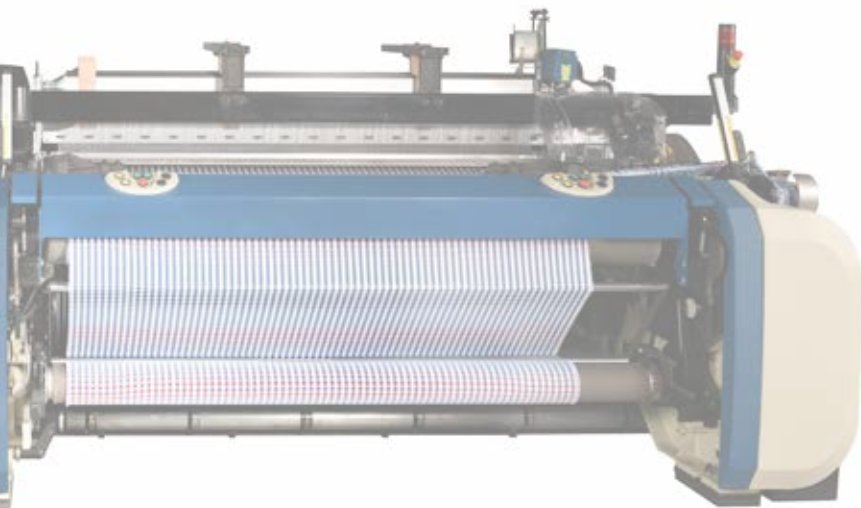

AUTOSPEED

Adapts the machine speed to the behavior of the filling yarn. Information from the filling detector is centrally processed and if conditions allow it, the microprocessor changes the machine speed and adapts the other machine settings to this new situation – all fully automated. Meanwhile, the machine stop level is constantly monitored, to make sure that limits set by the user are not exceeded. Autospeed can result in an average speed increase up to 5 %.

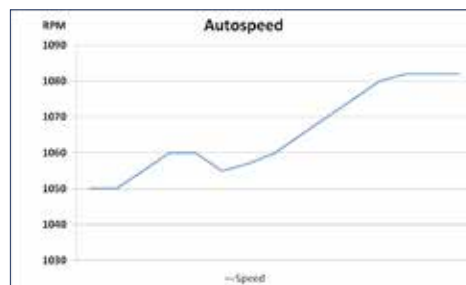

GET THE MOST
OUT OF YOUR TIME 

QUICK STYLE CHANGE (QSC)

Unique system with split frame concept. Preparation of new styles can now be done outside the weaving room. A prepared module makes it possible to change the style on a machine in a very short time. Significantly increases the efficiency of the entire weaving room.



Quick beam gear lock

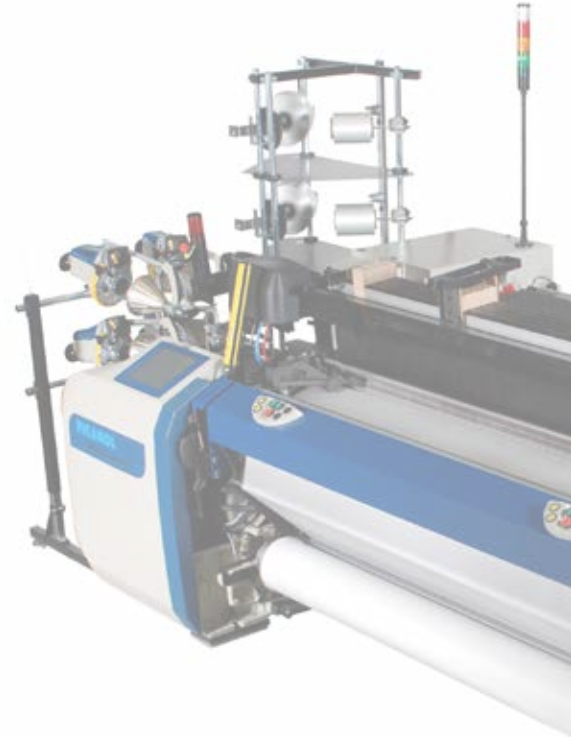

Easy cloth roll lock

Electronic Leno System (ELSY): drawing in of ends made easy



DRC30 harness frame height can easily be adjusted



WEFT FEEDERS

Picanol offers a range of weft feeders with mechanical or electronic adjustment of the yarn length. The Blue22 weft feeder simplifies the adjustment of the waste by means of a single mechanical screw.

The Blue22 Easyset function is entirely controlled via the terminal and eliminates the hassle of mechanical adjustments with special calibration tools.

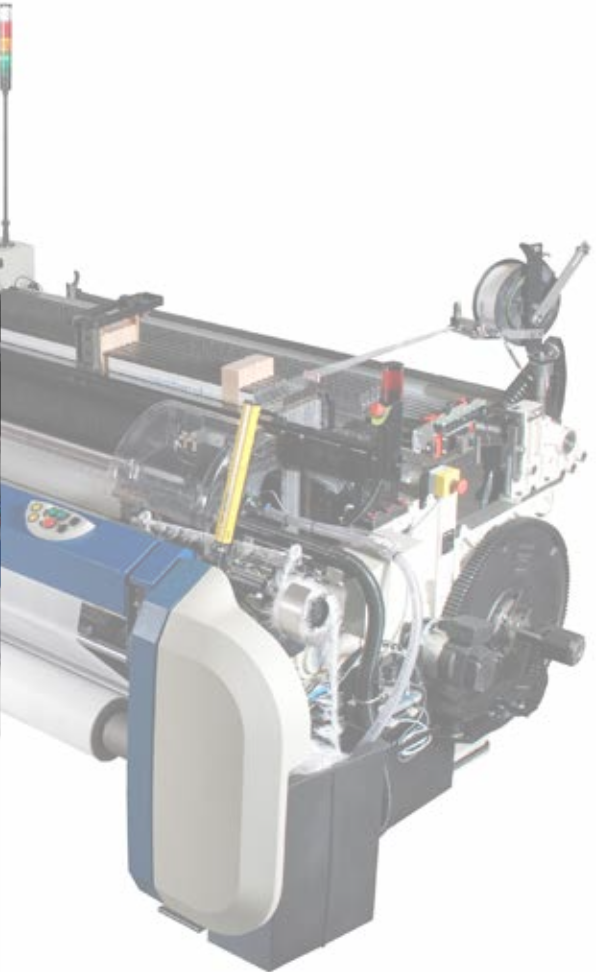

CORDLESS

No more need for a catch cord on the right-hand side, thus affording higher speeds and improved filling tension. From an operational as well as a logistic point of view, the Cordless system reduces the workload significantly. This unique feature is compatible with cut reed.

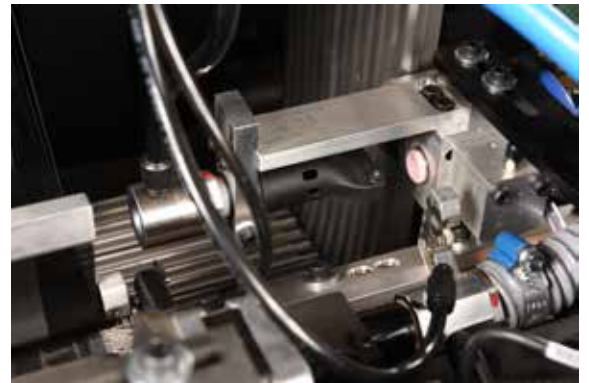

CENTRALIZED LUBRICATION

High-pressure oil pump brings oil from the central reservoir to machine parts that require constant lubrication. The oil is constantly filtered and the pressure constantly monitored, assuring long lifetime of crucial machine parts.

Centralized lubrication is far more reliable than splash lubrication. Less maintenance: changing oil can be done very quickly as all the oil can be taken from the central oil reservoir.



GET THE MOST
OUT OF YOUR TIME 

INTERACTIVE DISPLAY

A high-quality color touchscreen allows easy access and navigation during setup and weaving. All settings combined in easy-to-understand screens.



PRESSURE FOR MAIN AND RELAY NOZZLES SET FROM DISPLAY

Thanks to the unique configuration of the pressure regulators, air pressure is displayed in Bars - a direct and easily understandable reading. Pressure for the main and relay nozzles is managed completely digitally from the machine's terminal. The pressure settings can easily be monitored by a central system or transferred to another machine weaving the same style.

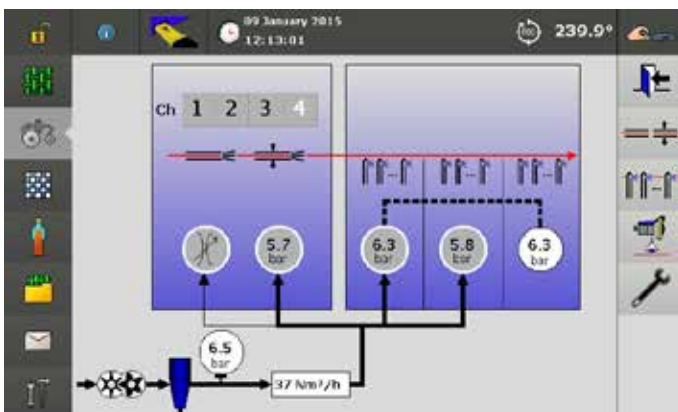
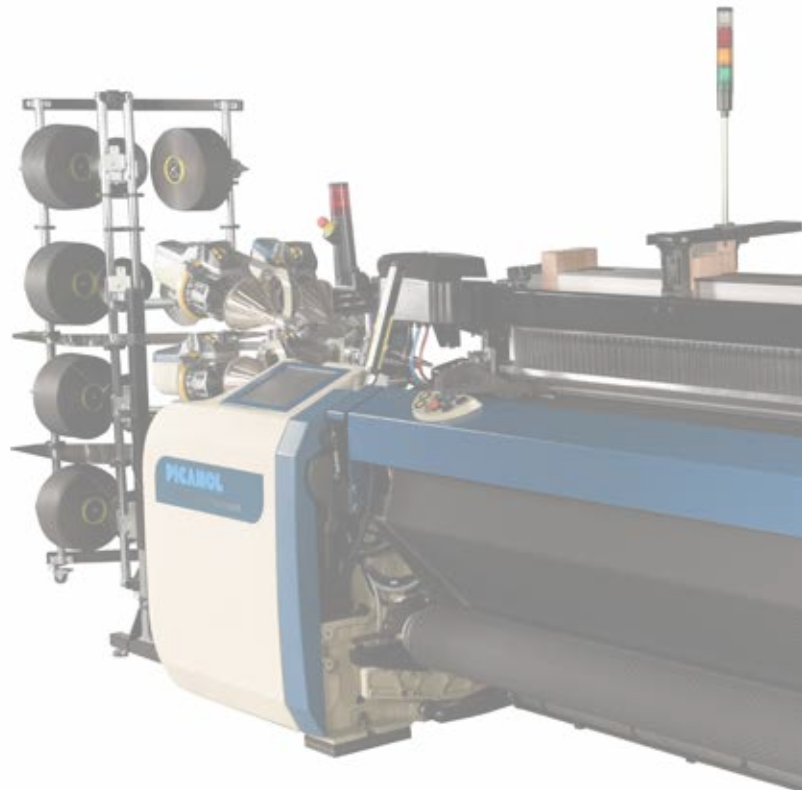

PC SUITE

Full set of tools to run a weaving shed in the most efficient way: manage machine settings with Picanol Style Administration, create new designs using Picanol Pattern Editor, get access to the production monitoring figures from a central computer using LoomGate and much more.

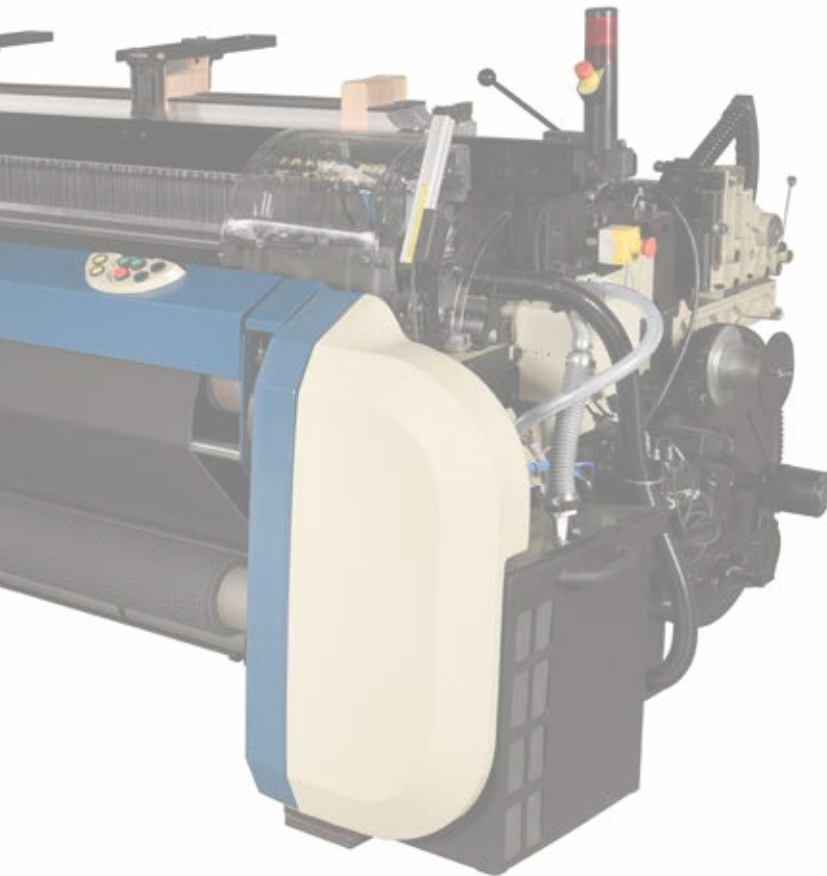
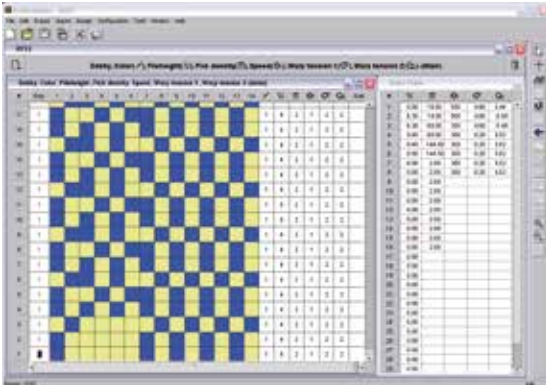

FIX A MARK

Avoiding starting marks has never been easier. All available functions and tools are combined in the “Fix-A-Mark” overview screen. The user can adapt the machine behavior in a very easy way, following observations made on the fabric itself.



GET THE MOST 
OUT OF YOUR TALENT



FABRIC SPECIFICATIONS

Useful widths	190, 220, 230, 250, 280, 340, 360, 400 cm
Width reduction	190 cm: up to 70 cm
(Both symmetrical and asymmetrical width reduction)	220 and 250 cm: up to 90 cm 280, 340, 360 and 400 cm: up to 96 cm
Spun yarns	Nm 4 - Nm 170, Ne 2.4 - Ne 100
Filament yarns	10 denier - 1000 denier, 11 dtex - 1100 dtex

FILLING INSERTION

Bobbin change detector		Optional
Up to 8 colors		Standard
Prewinders	Adjacent windings	Blue22 (patent pending)
(integrated bobbin break sensor)	Seperated windings	Blue22 EasySet (patent pending) 1131
Prewinder Switch-Off (PSO)		Optional
Double or multi-pick insertion (up to 8-pick)		Optional
Programmable Filling Tensioner (PFT)		Optional
Picanol Knot Extractor (PKE)		Optional
Balloon breakers		Optional
Fixed and movable main nozzles (patented)		Standard
Clamp on movable main nozzles (patented)		Optional
Electronic Low Continuous Airflow (ELCA) (patented)		Standard
Adaptive Relay Valve Drive (ARVD II Plus) (patented)		Optional
Airmaster (patented)		Optional
Electronic filling cutter with separate cutting time per color		Standard
Single- or multi-hole relay nozzles		Standard
Filling detection	Photoelectric, in front or next to the reed	Standard
	Second filling detector in front or next to the reed	Optional
	Argus filling detector	Optional
Pick Repair Automation (PRA II Plus) (patent pending)		Optional

WARP BEAM













Warp beam diameter	805, 1000 or 1100 mm	Standard
Double warp beam for reed width 280 cm and more		Optional
Fancy beam		Optional
Warp stop motion	Electrical, toothed electrodes and search handle	Standard
	Detection per electrode or per zone	Optional
Quick Style Change (QSC)		Optional

BACKREST

Universal type with built-in warp tension sensor		Standard
Warp tension sensors mounted in the warp (TSW)		Optional
Warp tension compensation (spring)		Standard
Easing motion (automatic warp tension compensation)		Optional

MACHINE DRIVE AND CONTROL (BLUEBOX PLATFORM)

SUMO motor with direct machine drive (patented)		Standard
Reed motion	Conjugated cams with cam followers	Standard
Shedding motion	Positive cams for up to 8 or 10 harness frames	Standard
	Positive dobbie for up to 16 harness frames	Standard
	Electronic Jacquard Control	Standard
	Automatic Crossing Moment (ACM)	Standard

Asymmetrical cam motion profile	Optional
Harness frames for 330 mm (13") heddles	Optional 
Automatic shed leveling with cam motion	Optional
Harness drive DRC-30	Standard
Fully automated pick finding (patented)	Standard
Pressurized oil circulation system with continuous filtration	Standard
Interactive display 9" touchscreen	Standard
12" touchscreen	Optional 
Autospeed (patented)	Optional 
Flexispeed	Standard
Multispeed or Optispeed	Optional 
Load-cell Electronic Let-Off (ELO) and Take-Up (ETU) system	Standard
HARNESSES FRAMES	
Extra reinforced harness frames	Standard
Hybrid harness frames	Optional
SELVEDGE	
E-Leno rotary selvedge unit	Standard 
Independent electronic Leno system (ELSY)	Optional 
Full-width temple	Optional 
Mechanical or Air tucking-in (patented) for single or multi-panel	Optional 
Hot-wire cutter for filament yarns	Optional 
Cordless version (cut reed) (patent pending)	Optional 
MONITORING & SOFTWARE TOOLS	
Loom monitoring and reporting on machine display	Standard
Universal connection for major weaving room monitoring systems	Standard
Bi-directional communication on ethernet or serial connection	Optional 
Picanol PC Suite	Optional 
BATCHING MOTION	
Picanol Batching Motion for diameters up to 1500 mm	Optional
Double pressure roller on batching motion	Optional 
SAFETY	
Light curtain (depending on country of delivery)	Standard

How to read the name

OMS - F - 4 - R 190

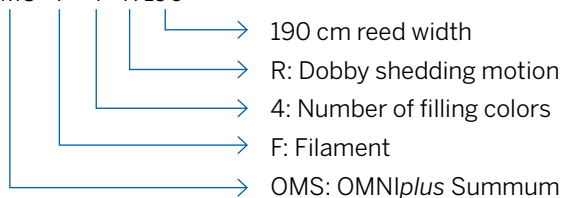

Regulations

In designing the OMNIplus Summum, Picanol has taken into account current international regulations concerning safety (mechanical and electric) and the environment (ergonomics, noise, vibrations, and electromagnetic compatibility).

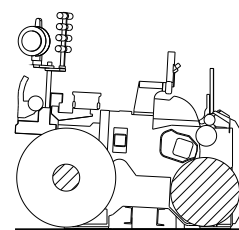
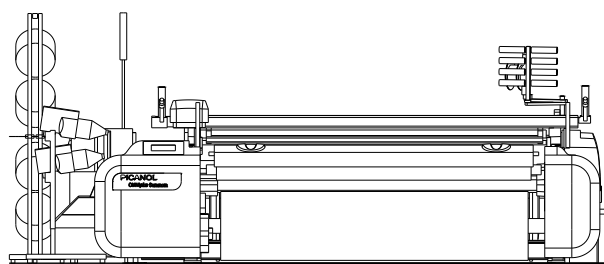

Minimum dimensions OMNIplus Summum 2-P 190



Growing is the essence of weaving.

Thread by thread, line by line, from the most basic to the most exquisite, a wide range of fabrics emerge from our weaving machines. That's why Picanol offers a wide variety of machines and services that enable weavers to create every fabric imaginable.

Growing is the essence of doing business.

The relentless pursuit to weave faster, better and more cost-efficiently is what drives you, and motivates us. That's why we make our machines ever more energy-efficient, user-friendly and easy to set.

Growing is the essence of the future.

The world changes quickly, and only those who are ready to learn and adapt will survive. That's why Picanol machines are sustainable, future-proof and intelligent machines that can adapt to changing circumstances and connect with each other. And that's why at Picanol, we want to be an intelligent organization that listens to our customers and develops together with them.

Because our goal is to Grow Together.

With you, our customers and partners.

We will grow together by removing all the obstacles and conventions holding back your ambition and our imagination. We will grow together by enabling your continued access to the latest technology. We will grow together by inspiring each other, listening to each other and learning from each other.

We truly believe that the future holds tremendous opportunities for growth. Let's grab them.

Let's grow together



**LET'S GROW
TOGETHER** 

letsgrowtogether.be

Picanol nv
Steверlyncklaan 15
BE-8900 Ieper
Belgium
Tel. +32 57 222 111
Fax +32 57 222 001
www.picanol.be
info@picanol.be

PICANOL